

SAFE-T-COVER™

Specification Submittal Sheet

Series 600 – Panel Design

Insulated Enclosure for Backflow Prevention Assemblies

Materials

- Roof, walls, panels, drain panel – 5052-H32 marine grade aluminum (.050/18 gauge), mill finish, ASTM B209 outside
- Drain panel hinge and spring – stainless steel
- Insulation 1 1/2 " (10.0 "R" value) minimum thickness polyisocyanurate foam laminated to a glass fiber reinforced facer (each side)
- Mounting Hardware – 300 series stainless steel or T-6 aluminum
- Hex head fasteners – coated and self tapping with seal washer
- Masonry fasteners – stud type Hilti Kwik Bolt II™ wedge anchors

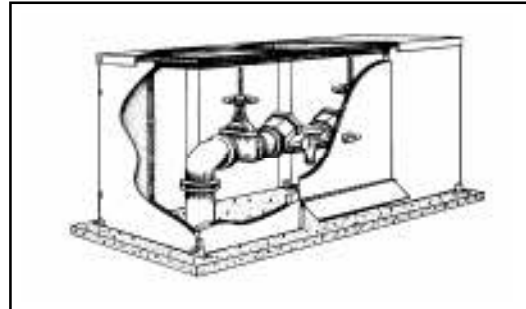

Description

The enclosure is designed to provide freeze and vandal protection of above ground backflow prevention assemblies. The enclosure provides for safe and easy testing and maintenance or replacement of the backflow prevention assembly.

Standards

- ASSE 1060 
- ASTM B209

Heating Required

- Yes – see separate specification submittal sheet
- No

Dimensions and Weights

| Model Number | Inside Diameter (in) | | | Concrete Pad (in) | | | Weight | Access | Access Panel Size (in) | | Drain Opening (in) | |
|----------------|----------------------|-----|----|-------------------|-----|---|--------|--------|------------------------|----|--------------------|-------|
| | W | L | H | W | L | H | | | W | H | W | H |
| 600-AL | 36 | 100 | 56 | 50 | 114 | 6 | 364 | 2 | 38 1/4 | 56 | 38 1/4 | 6 1/2 |
| 600D-AL | 70 | 108 | 56 | 84 | 122 | 6 | 535 | 2 | 38 1/4 | 56 | 38 1/4 | 6 1/2 |
| 600DS-AL | 70 | 128 | 56 | 84 | 142 | 6 | 575 | 4 | 38 1/4 | 56 | 38 1/4 | 6 1/2 |
| 600LU880-AL* | 36 | 38 | 48 | 50 | 52 | 6 | 245 | 2 | 28 | 48 | 28 | 6 1/2 |
| 600S-AL | 38 | 120 | 56 | 52 | 134 | 6 | 434 | 2 | 38 1/4 | 56 | 38 1/4 | 6 1/2 |
| 600T-AL | 36 | 100 | 64 | 50 | 114 | 6 | 424 | 2 | 38 1/4 | 64 | 38 1/4 | 6 1/2 |
| 600TD-AL | 70 | 108 | 64 | 84 | 122 | 6 | 565 | 2 | 38 1/4 | 64 | 38 1/4 | 6 1/2 |
| 600TDS-AL | 70 | 128 | 64 | 84 | 142 | 6 | 590 | 4 | 38 1/4 | 64 | 38 1/4 | 6 1/2 |
| 600TLU880-AL * | 44 | 38 | 48 | 58 | 52 | 6 | 212 | 2 | 36 | 48 | 36 | 6 1/2 |
| 600TS-AL | 38 | 120 | 64 | 52 | 134 | 6 | 524 | 2 | 38 1/4 | 64 | 38 1/4 | 6 1/2 |

* standard compact design models include hinged lift-up roof

Specifications

A freeze and vandal protection enclosure shall be installed with above ground backflow prevention assemblies. The enclosure shall be mounted securely to a concrete pad and assembled in such a way that it will remain locked and secured to pad even if outside screws are removed. The enclosure shall be constructed of 5052-H32 marine grade aluminum with a minimum R-value of 10 in the walls and panels and R-value of 20 in the roof. Drain panel shall be fully insulated and designed to remain closed except when backflow prevention device is discharging water. Drain panel shall be sized to accommodate the maximum discharge of the device. All mounting hardware shall be furnished. The enclosure shall be certified to ASSE Standard 1060 (Class I, Class II, and Class III). The insulated enclosure shall be a Safe-T-Cover Series 600.