

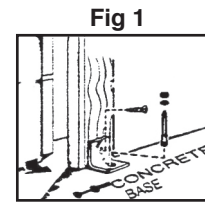

Assembly Instructions

Series 75/100/200/300/400 SN

Anchored Enclosures

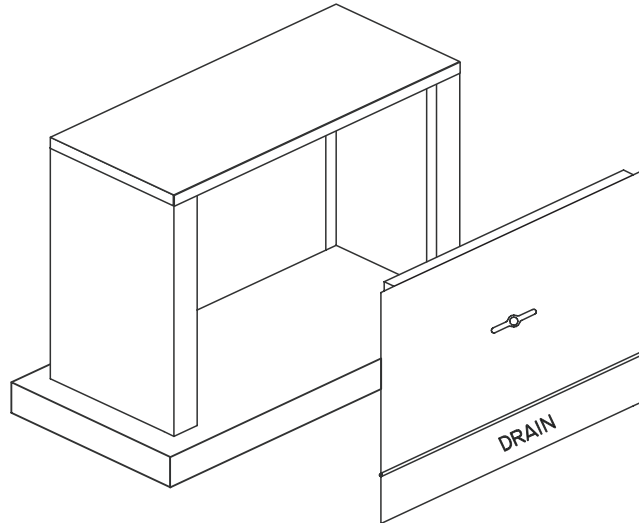

Dimensions

Model	Inside Dimensions	Concrete Pad
75SN-AL	9" X 26" X 25"	16" X 33" X 4"
100SN-AL	14" X 40" X 30"	21" X 47" X 4"
100SNT-AL	15" X 32" X 38"	22" X 39" X 4"
200SN-AL	18" X 46" X 38"	25" X 53" X 4"
300SN-AL	24" X 60" X 38"	38" X 74" X 6"
400SN-AL	27" X 78" X 57"	41" X 92" X 6"

Instructions

1. Pour a 4" thick concrete base for models 75SN through 200SN. Pour a 6" thick concrete base for the 300SN and 400SN. Place expansion material around riser pipes and place conduit for electrical power before placing concrete. CONCRETE SHOULD BE FINISHED ABSOLUTELY LEVEL, FLAT AND SMOOTH. Allow concrete to cure.
2. Using one (1) hexhead screw and one (1) wedge anchor for each aluminum bracket attach Inside Anchoring Brackets to side and end panels and concrete (FIG 1).
3. Set access door panel and lock in place. (Solid front panel to be ACCESS door).
4. Access to the top of the enclosure can be accomplished by unlatching the inside roof latch.
5. Provide ground-fault interrupter device in electrical circuit according to applicable codes. Install heater as per manufacturer's instructions and governing local and national codes.
6. For maximum protection it is suggested that the area between the bottom of the enclosure and the concrete base be caulked with the exception of the door panel. DO NOT CAULK THE BOTTOM OF THE DOOR PANEL.

Remove masking film IMMEDIATELY after installation!